



PSAC 04244
v.1.1

PSAC 24VAC/4A/4x1A
AC power supply for CCTV

EN

Edition: 3 from 29.10.2012
Supersedes the 2 edition from 14.07.2011



Features:

- power output 4x 1A/24V AC or 27V AC
- power voltage 230V AC
- 4 outputs protected independently by 1A fuses
- jumper selectable fuse type: glass fuse or polymer fuse
- LED indication
- AW technical output indicating failure
- protections:
 - SCP short-circuit protection
 - OLP overload protection
 - OHP overheat protection
 - surge protection
 - against tampering
- warranty – 5 year from the production date

CONTENTS:

1. Technical description.

1.1 General description

1.2 Block diagram

1.3 Description of PSU components and connectors

1.4 Specifications

2. Installation.

2.1 Requirements

2.2 Installation procedure

3. Operating status indication.

3.1 LED indication

3.2 Technical outputs

4. Operation and use.

4.1. Overload or short circuit at the PSU output

4.2. Maintenance

1. Technical description.

1.1. General description.

The AC/AC **PSAC 04244** PSU intended for supplying CCTV system devices requiring voltage of **24 V AC** or **27 V AC** and total capacity of **4A@24 V AC**. It features 4 outputs protected independently with glass or polymer fuses. Output voltage range is step-adjustable by appropriate jumpers, independently for each AUX output. The PSU is housed in a metallic enclosure that features a microswitch indicating unwanted opening of the front door (faceplate).

1.2. Block diagram.

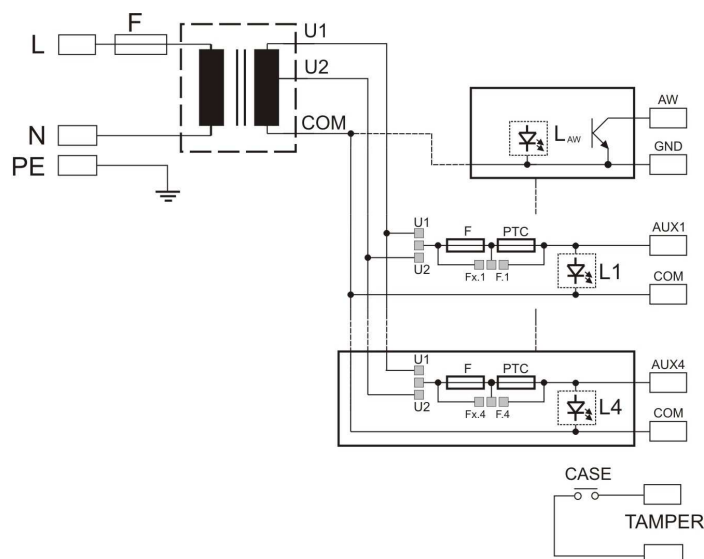





Fig.1. Block diagram of the PSU.

1.3. Description of PSU components and connectors

Tab.1. Terminals and elements of LB4/24V/27V/AW- fuse strip (module).

Element no. [Fig. 2]	Description
[1]	L1÷L4 - LEDs (green) indicating L1=AUX1 output status
[2]	F1÷F4 fuses in AUX circuits, F1=AUX1 etc.
[3]	COM-U1-U2 AC power input
[4]	AUX1÷AUX4 – outputs, joint terminal COM
[5]	L _{AW} red LED indicating failure at one of the outputs (fuse activation)
[6]	AW output indicating failure at one of the outputs, OC type (L – normal state, hi-Z - failure)
[7]	Jumper for fuse selection (glass fuse or polymer fuse) Fx Fx.x  Fx jumper on, glass fuse selected Fx Fx.x  Fx.x jumper on, polymer fuse selected
[8]	Selection jumper for AUX output voltage (independently for each output): U2 U1  U1 jumper on, voltage at the output AUXx= 24V AC U2 U1  U2 jumper on, voltage at the output AUXx= 27V AC

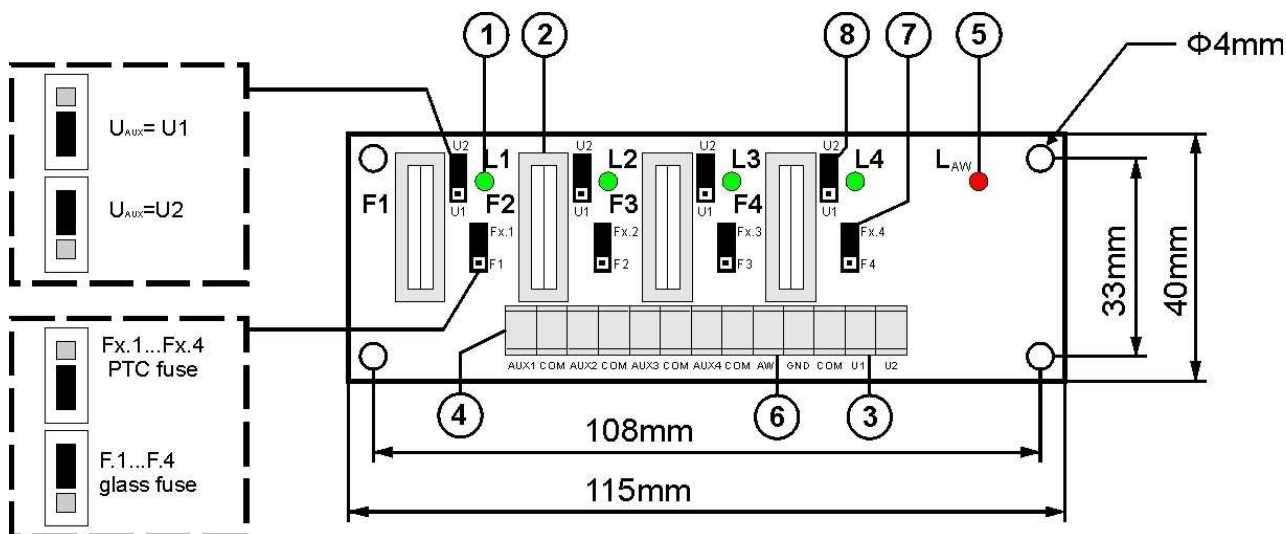



Fig.2. View of the LB8/24/27/AW strip.

Tab.2. Terminals and elements of the PSAC 04244 power supply unit.

Element no. [Fig. 4]	Description
[1]	Isolation transformer
[2]	Fuse strip (module) LB4/24V/27V/AW (tab. 1)
[3]	TAMPER, tampering connector (NC)
[4]	F fuse in the power supply circuit (230 V AC)
[5]	L-N connector 230V/AC,  PE protection connector

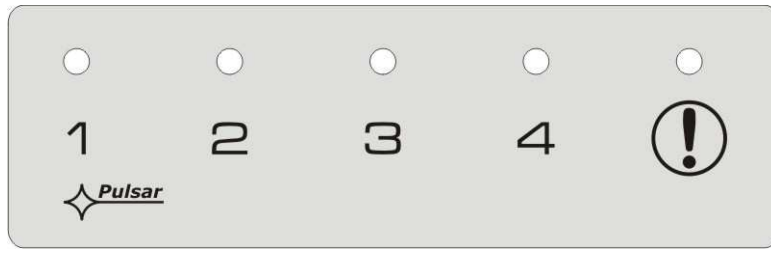

Fig.3. The view of the PSU's panel.

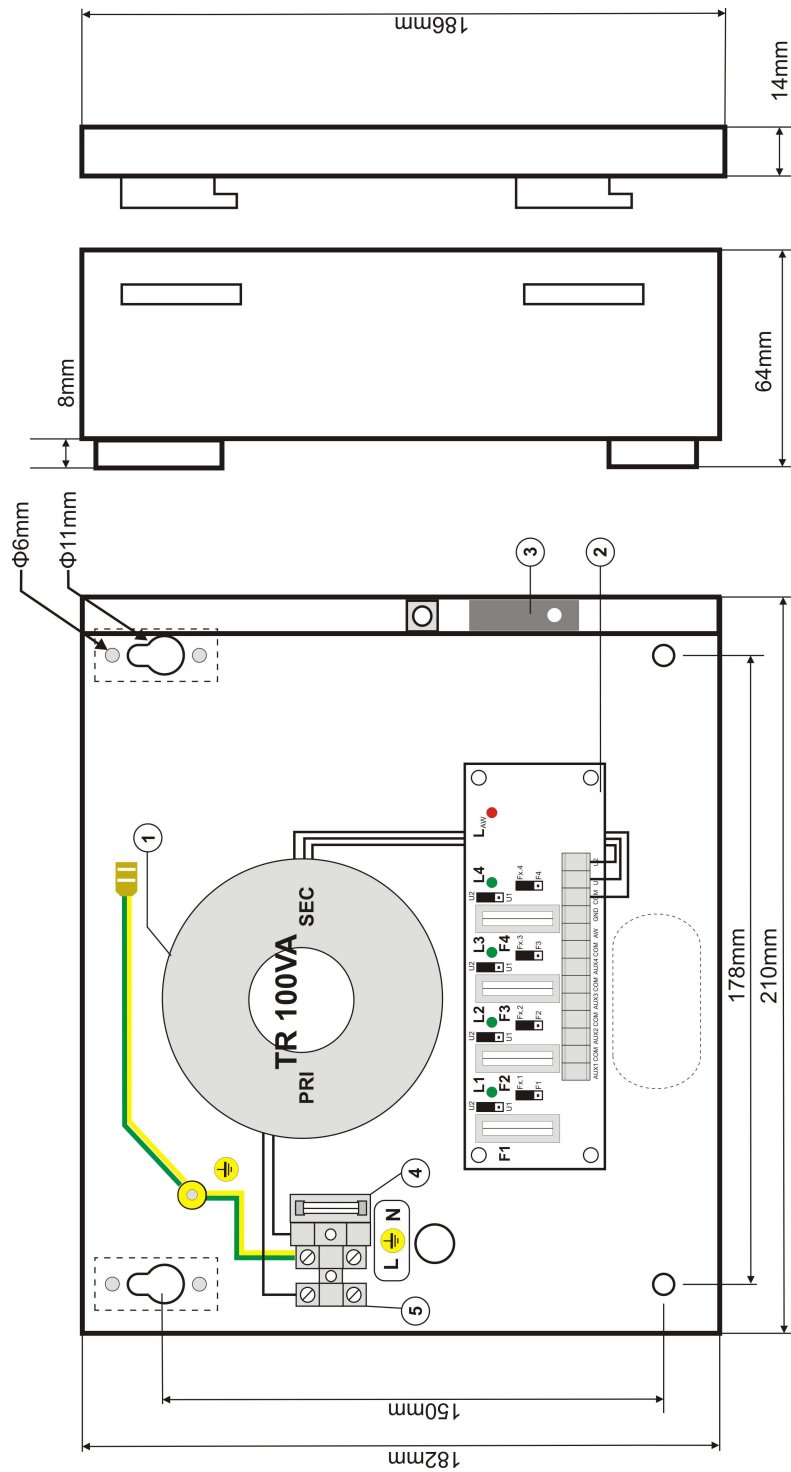

Fig.4. The view of the PSU.

1.4 Specifications:

- electrical specifications (tab.3)
- mechanical specifications (tab.4)
- operation safety (tab.5)
- operating specifications (tab.6)

Electrical specifications (tab. 3).

Mains supply	230 V AC (-15%/+10%)
Current consumption	0,5 A max.
Power frequency	50 Hz
Power of the S PSU	100 VA max.
Output voltage	U1 : 23÷28 V AC (100% load ÷ 0% load) U2 : 25,5÷31,5 V AC (100% load ÷ 0% load)
Output voltage adjustment range	U1/U2 (jumper selectable)
AUX output current	4x 1A Σ 4,0 A@24 V AC max or 4x 0,9A Σ 3,7 A@27 V AC max
Short-circuit protection SCP	4x F 1A glass or 1A polymer fuse - glass fuse damage requires fuse-element replacement
Overload protection OLP	circuit AC 24 V : 4x F 1,0A or PTC 1A circuit AC 230V : T 1A
Surge protection	varistors
Overheat protection OHP	inside transformer
Sabotage protection: - TAMPER output indicating enclosure opening	- microswitch, NC contacts (enclosure closed), 0,5A@50 V DC (max.)
Technical outputs: - AW output indicating failure at one of the AUX outputs (fuse activation)	- type OC, 50mA max. normal state: level L (0 V) failure: hi-Z level
LED indication: LEDs L1÷L4 (green) LED L _{AW} (red)	- AUX1...AUX4 output status correct operation = on failure = off - failure indication, at min. one AUX outputs correct operation = off failure = on
F fuse F1÷F4 fuse	T 1 A/ 250 V F 1A/ 250 V or PTC 1A

Mechanical specifications (tab. 4).

Enclosure dimensions	210 x 182 x 64 (215 x 187 x 56+8) (WxHxD) [mm] (+/-2mm)
Fixing	178 x 150 x Φ 6 (W x H)
Net/gross weight	2,09 kg / 2,23 kg
Enclosure	Steel plate DC01 0,7mm thick, colour RAL9003
Closing	Cheese head screw (at the front)
Connectors	Power: Φ 0,63÷2,50 (AWG 22-10) Outputs : Φ 0,41÷1,63 (AWG 26-14), TAMPER output : cables' length: 30cm
Notes	The enclosure does not adjoin the assembly surface so that cables can be led. Convictional cooling.

Operation safety (tab.5).

Protection class PN-EN 60950-1:2004	I (first)
Protection grade PN-EN 60529: 2002 (U)	IP20
Electrical strength of insulation: - between input (network) circuit and output circuits of the PSU (I/P-O/P) - between input circuit and PE protection circuit (I/P-FG) - between output circuit and PE protection circuit (O/P-FG)	3000 V/AC min. 1500 V/AC min. 500 V/AC min.
Insulation resistance: - between input circuit and output or protection circuit	100 M Ω , 500V/DC

Operating specifications (tab.6).

Operating temperature	-10°C...+40°C
Storage temperature	-25°C...+60°C
Relative humidity	10%...90% without condensation
Vibrations during operation	unacceptable
Impulse waves during operation	unacceptable
Direct insolation	unacceptable
Vibrations and impulse waves during transport	PN-83/T-42106

2. Installation.**2.1 Requirements**

The AC/AC power supply is to be mounted by a qualified installer, holding relevant permits and licenses (applicable and required for a given country) for 230V/AC interference and low-voltage installations. The unit should be mounted in confined spaces, in accordance with the 2nd environmental class, with normal relative humidity (RH=90% maximum, without condensation) and temperature from -10°C to +40°C (table 6). The PSU shall work in a vertical or horizontal position.

Before mounting the PSU module, perform a load balance. During normal operation, total current drawn by the receivers cannot exceed **I=4,0A@24 V AC**. As the PSU is designed for a continuous operation and is not equipped with a power-switch, therefore an appropriate overload protection shall be guaranteed in the power supply circuit. Moreover, the user shall be informed about the method of unplugging (usually through assigning an appropriate fuse in the fuse-box). The electrical system shall follow valid standards and regulations.

2.2 Installation procedure.

1). Before installation, make sure that the voltage in the 230V power-supply circuit is cut off.

2). Mount the PSU in a selected location and connect the wires.

3). Connect the power cables to the L-N terminals. Connect the ground wire to the terminal marked by the earth symbol – “⊕”. Use a three-core cable (with a yellow and green PE protection wire) to make the connection. Lead the cables to the appropriate terminals of the connection board through the bushing.



The shock protection circuit shall be performed with a particular care, i.e. the yellow and green wire coat of the power cable shall stick to one side of the terminal marked with the '⊕' earth symbol in the PSU enclosure. Operation of the power supply without a properly made and fully operational shock protection circuit is UNACCEPTABLE! It can result in device damage or an electric shock.

4). Connect the receivers' cables to the AUXx- COM connectors of the terminal block on the LB4/24V/27V/AW pcb.

5). If necessary, connect the devices' wires (alarm panel, controller, indicator, etc.) to the PSU's technical outputs:

- **AW** output indicating fuse activation (output of the LB4/24V/27V/AW strip)
- **TAMPER** output indicating unwanted opening of the PSU enclosure

6). In case of installation where significant voltage drops occur in the resistance of the cables leading to the receivers, there is a possibility of (step) voltage value correction by the U1/U2 jumpers. Adjustment in the output voltage value 24V AC/27V AC is independent for each AUX output.

7). Restore the mains power ~230 V AC.

8). Check the LED indication for PSU operating status: LEDs L1÷L4 (green) should be constantly illuminated.

9). Once the installation and operation control have been completed, the enclosure can be locked.

3. Operating status indication.

The PSU is equipped with LED indication of operation status. The presence of power at the outputs of the PSU is indicated by the illumination of green LEDs on the PCB of the LB4/24V/27V/AW strip (module). A failure is indicated by a red LED [!] AW. The PSU status can be remotely controlled through the AW technical output.

3.1 LED indication.

- L1....L4 green LEDs indicate power at the outputs: AUX1.....AUX4.
- In case of a power loss at the output (fuse burn/PTC activation), an appropriate diode goes out (L1 for AUX1, L2 for AUX2 etc.).
- LED [!] AW red diode indicates a failure at the at least one AUX output (output number is indicated by a green diode).

3.2 Technical outputs.

The PSU has some indication outputs that enable providing information about a failure or tampering.

- AW – output indicating a fuse failure (output of the LB4/24V/27V/AW strip).
In a normal status (under proper operation), the AW technical output is fault to ground (GND). When any of the fuses get damaged, the output is switched into hi-Z - high impedance state. The failure status is also indicated by the L_{AW} red diode.

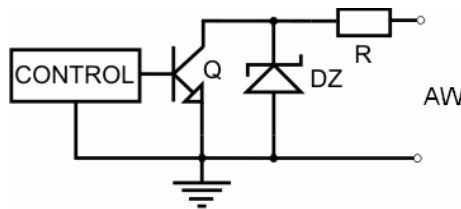

Fig. 5. Electrical diagram of OC output.

- TAMPER - output indicating unwanted opening the power-supply unit, volt-free (potential-free) contacts in the output indicate the door status, unit closed: NC, unit opened: NO

4. Operation and use.

4.1 Overload or short circuit at the PSU output

The AUX1÷AUX4 PSU outputs are protected against a short circuit with glass or polymer fuses. In case of fuse damage, the replacement of the same parameters is required.

If the polymer fuse-assisted protection has been chosen, there will be an automatic disconnection of the output voltage indicated by the green diode going out. Then, cut off the load from the PSU output for approx. 1 minute.

If the PSU is loaded with current exceeding $\Sigma 4,0A @ 24 V AC$ (110%for ÷ 150% of S power), there occurs the F fuse damage in the 230 V AC circuit and/or F1÷F4 fuses. In case of a failure, replace the fuse of the same parameters.

4.2 Maintenance.

Any and all maintenance operations may be performed following the disconnection of the PSU from the power supply network. The PSU does not require performing any specific maintenance measures. However, in case of a significant dust level, clean the interior with compressed air. In case of a fuse replacement, use one of the same parameters.

**WEEE MARK**

According to the EU WEE Directive – It is required not to dispose of electric or electronic waste as unsorted municipal waste and to collect such WEEE separately.

GENERAL WARRANTY CONDITIONS

1. Pulsar K. Bogusz Sp.j. (the manufacturer) grants a five-year warranty for the equipment, counted from the device's production date.
2. The warranty includes free-of-charge repair or replacement with an appropriate equivalent (the selection is at the manufacturer's discretion) if the malfunction is due to the manufacturer, includes manufacturing or material defects, unless such defects have been reported within the warranty period (item 1).
3. The equipment subject to warranty is to be brought to the place where it was purchased, or directly to the main office of the manufacturer.
4. The warranty applies to complete equipment, accompanied by a properly filled warranty claim with a description of the defect.
5. Should the claim be accepted, the manufacturer is obliged to provide warranty repairs, at the earliest convenience, however not later than within 14 days from the delivery to the service centre of the manufacturer.
6. The repair period mentioned in item 5 may be prolonged, if there are no technical possibilities to carry out the repairs, or if the equipment has been conditionally accepted, due to the breaking warranty terms by the claimant.
7. All the services rendered by force of the warranty are carried out at the service centre of the manufacturer, exclusively.
8. The warranty does not cover the defects of the equipment, resulting from:
 - reasons beyond the manufacturer's control,
 - mechanical damage,
 - improper storage and transport,
 - use that violates the operation manual or equipment's intended use
 - fortuitous events, including lightning discharges, power failures, fire, flood, high temperatures and chemical agents,
 - improper installation and configuration (in defiance with the manual),
9. The warranty is void in any of the following circumstances:
 - construction changes
 - repairs carried out by any unauthorized service center
 - damage or removal of warranty labels
 - modifications of the serial number
10. The liability of the manufacturer towards the buyer is limited to the value of the equipment, determined according to the wholesale prices suggested by the manufacturer on the day of purchase.
11. The manufacturer takes no responsibility for the defects that result from:
 - the damaging, malfunctioning or inability to operate the equipment
 - defects that result from using the equipment outside its stated specifications and operating parameters failing to abide by the recommendations and requirements contained in the manual, or the use of the equipment.

Pulsar K.Bogusz Sp.j.

Siedlec 150,

32-744 Łapczyca, Polska

Tel. (+48) 14-610-19-40, Fax. (+48) 14-610-19-50

e-mail: biuro@pulsar.pl, sales@pulsar.plhttp:// www.pulsar.pl, www.zasilacze.pl